

DANEO 400

Hybrid Signal Analyzer for Power Utility Automation Systems



DANEO 400 – Hybrid measurement

DANEO 400 is a hybrid measurement system that records and analyzes all conventional signals (voltages, currents, hard wired binary status signals) and messages on the communication network in a digital substation. It measures signals from both of these worlds and can provide information to assess their proper coordination. With this device, you can easily keep track of what is going on in the substation by obtaining information on the operational status and communication.

Easy configuration and control

Easily configure and control one or more DANEO 400 units with the PC software DANEO Control. For controlling a single device, a selected feature set is also available via the built-in DANEO 400 web interface.

The control can be safely performed over the substation communication network without impairing the function of the substation automation system (SAS).

Distributed recording with multiple units

A measurement system with multiple DANEO 400 units obtains a time aligned view on signals covering the entire scope of a distributed SAS. All acquisition units are accurately time synchronized, using the precision time protocol (PTP) according to IEEE 1588-2008.



Network interfaces

Control interfaces

Extension interfaces



system

Fields of application

DANEO 400 is a useful tool that covers the whole life-cycle of a protection automation and control (PAC) system.

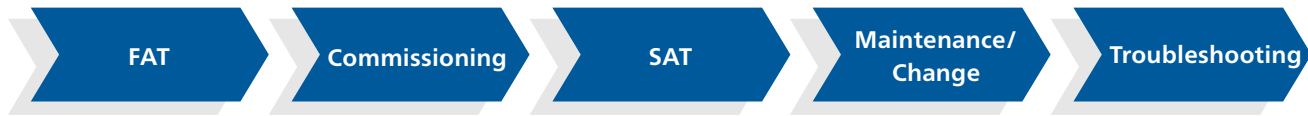

DANEO 400 can be used in all kinds of different PAC systems and network topologies:

- > Hybrid substation with conventional signals and network communication
- > Local area network (LAN) in local substations
- > Wide area network (WAN) between substations
- > Redundancy network topologies (e.g. HSR and PRP)

Main use cases

- > Fault recording (classical and hybrid)
- > Verification of IEC 61850 communication
- > Supervision of network traffic
- > Assessment of network performance

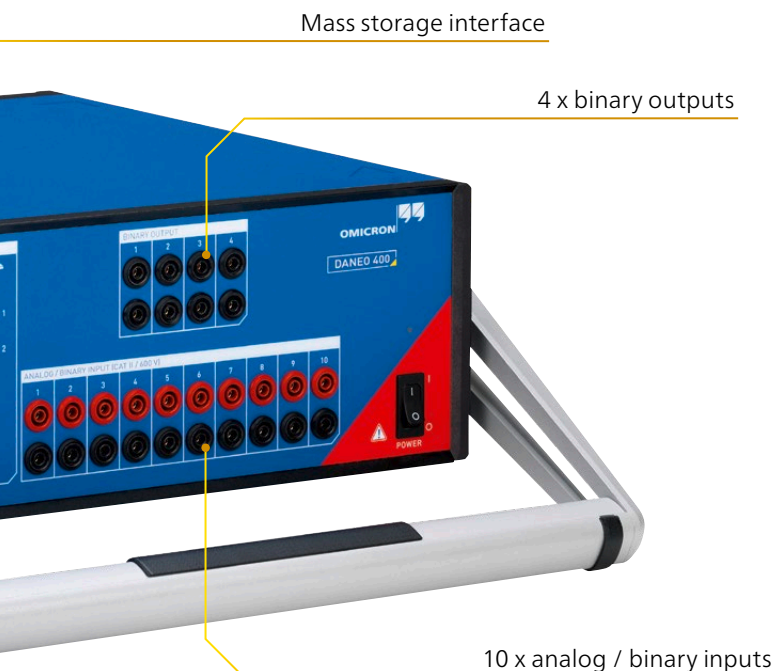

Your benefits

- > Easy to operate with DANEO Control software or web interface
- > Easy access to IEC 61850 information
- > Simultaneous processing of analog/ binary signals and network traffic
- > Analysis of distributed systems
- > Autonomous supervision of real-time traffic
- > Traces sporadic events in trouble-shooting

www.omicronenergy.com/DANEO400

One device – multiple use cases

Fault recording (classical and hybrid)

The occurrence of a malfunction in a PAC system is often unpredictable. Problems occur infrequently and under conditions which are not always known. When they do occur it is critical to resolve such issues. In troubleshooting, you often need to react to situations without any preparation and you have to improvise without access to the full documentation of the system. DANE0 400 helps you to find out what may be causing the malfunction.

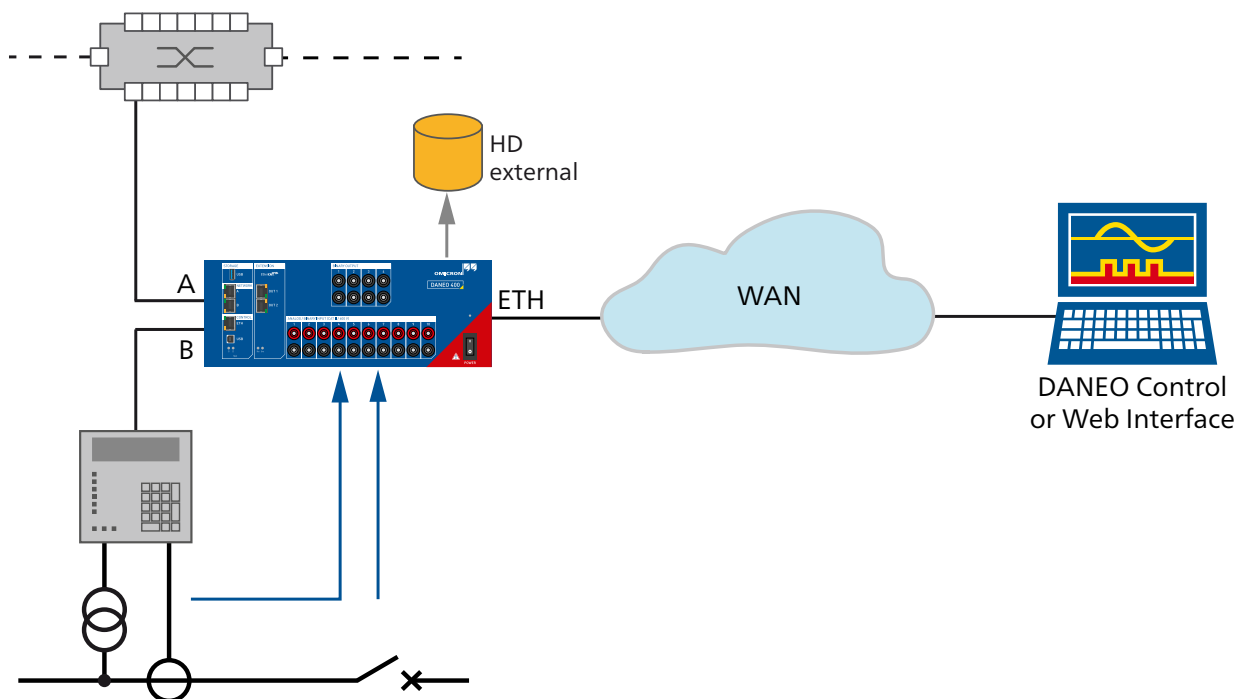

Unattended operation

The device works unattended in permanent or semi-permanent test setups. The detection of predefined trigger conditions starts the recording of signals and network traffic. The device re-arms itself to detect another occurrence of the fault and creates multiple recordings autonomously.

External storage

If large amounts of data are expected, an external hard drive can be connected for storing the recordings.

Remote control

With a remote connection to the DANE0 400 you can check the device status and download recordings for analysis. There is also a built-in web interface for easy access to the device with a web browser.

Verification of IEC 61850 communication

The IEC 61850 communication is a mission critical part of a PAC system. DANE0 400 supports you to easily verify, prove and document that your protection and control devices are working and communicating properly.

The description of the communication system in the standardized IEC 61850 substation configuration language (SCL) format serves as the basis for the verifications. It is verified that the IEC 61850 server of all IEDs are available and the substation network traffic is actually present on the communication network as defined.

As devices are put into operation one by one during commissioning, the verification can be performed incrementally without re-executing the checks for all devices already verified.

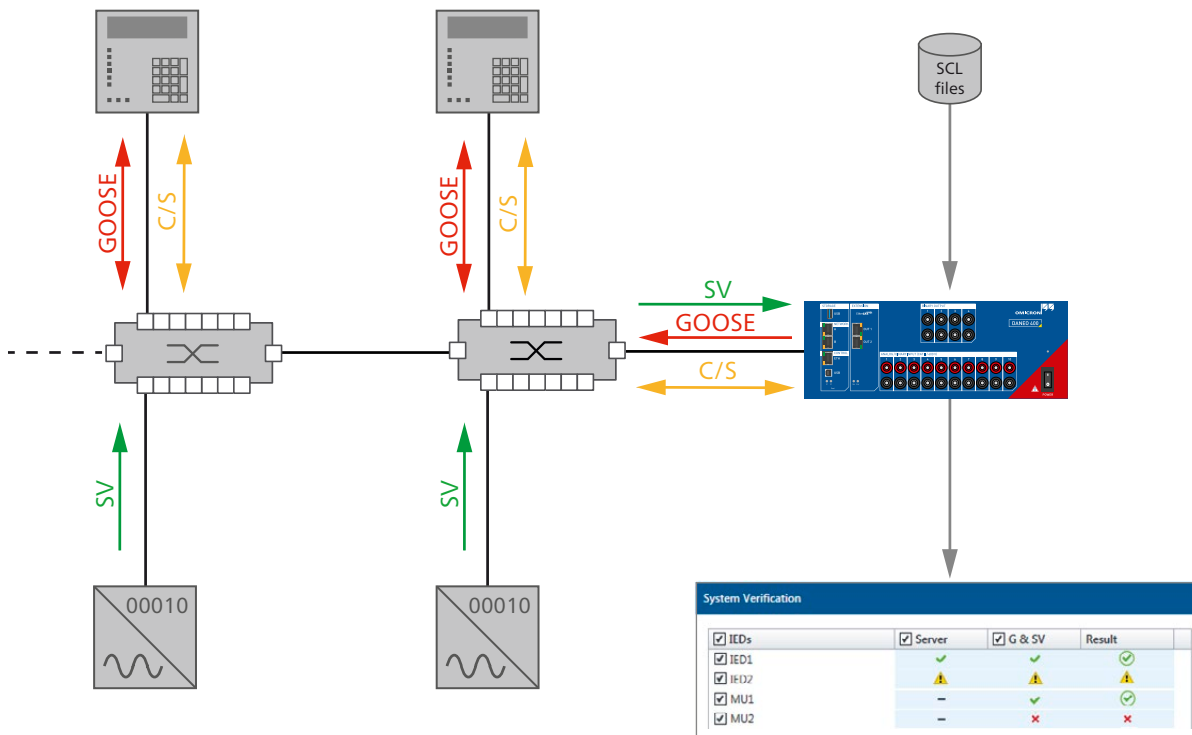

Debugging differences

If devices do not perform as desired, detailed information is provided for further investigation and debugging. The differences between the configuration and the traffic on the network is clearly visualized side by side.

Find orphan elements

All found GOOSE messages or sampled values streams which are not defined in the SCL files are listed as orphan elements.

One device – multiple use cases

Supervision of network traffic

During the normal operation of a PAC system, the IEC61850 network traffic is supervised so that any issues are detected immediately. The supervision is based on the SCL definition and constantly evaluates all network packets of GOOSE messages and Sampled Values streams.

The DANE0 400 detects abnormalities in the network traffic and automatically logs all events with the corresponding detailed information (e.g. lost samples, GOOSE timing problems, PTP time synchronization issues...). The event severity and category helps to filter and analyze the entries in the event log.

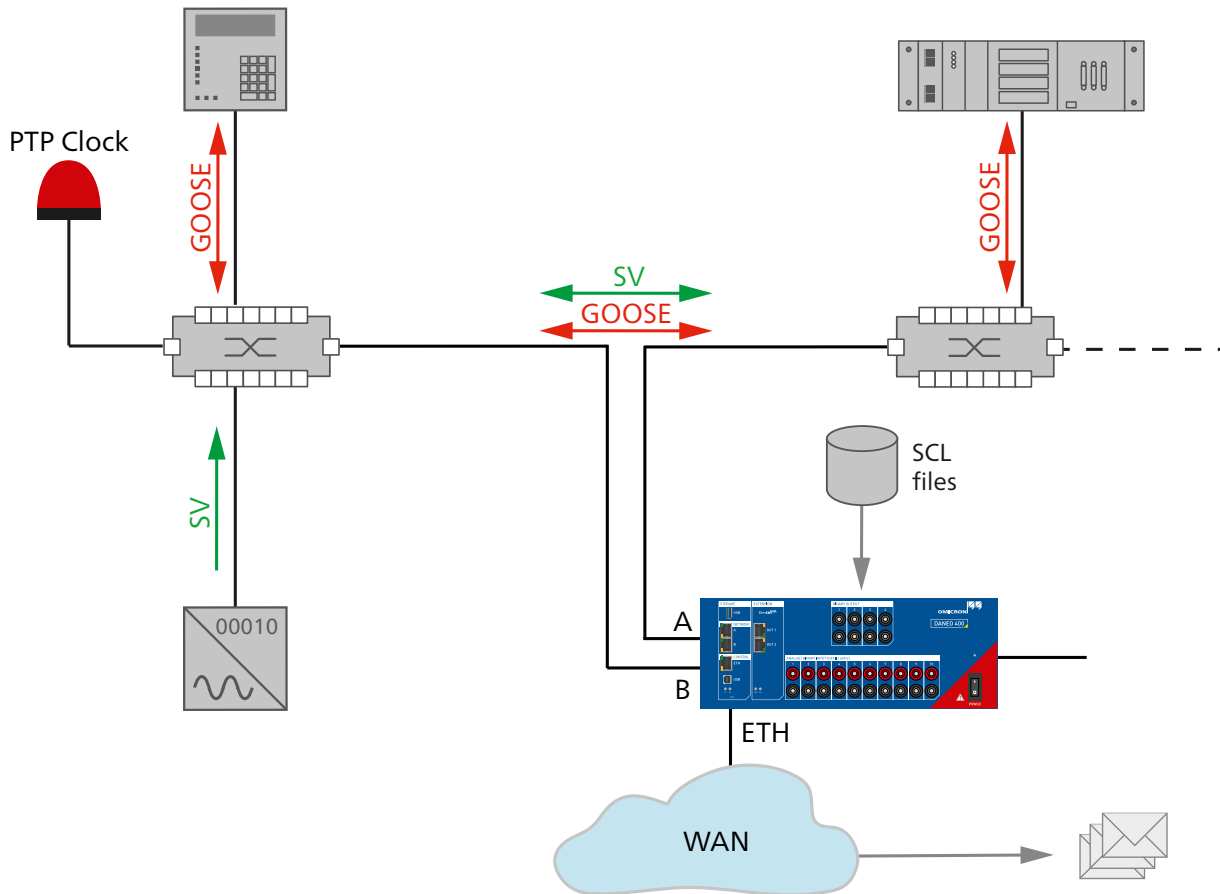

Actions

The occurrence of events can trigger recordings of the relevant data or send email notifications to inform the operating staff. Multiple actions with different event filters can be configured.

Network TAP mode

The DANE0 400 can be connected in passive TAP mode to the substation network. Thus, it can obtain all traffic on a link without the requirement to configure traffic monitoring in the Ethernet switches.

Network performance assessment

The correct functioning of the communication network is an essential precondition for the optimal performance of a PAC system. Consequently, the performance and load of the communication network needs to be measured and assessed on its own. Depending on the communication architecture and technologies deployed, different approaches are applicable.

DANEEO 400 measures and assesses the transfer of status information (e.g. GOOSE messages) within a local substation network or between substations. All involved devices are configured and controlled with the DANEEO Control software, even if they are connected over a wide area network (WAN).

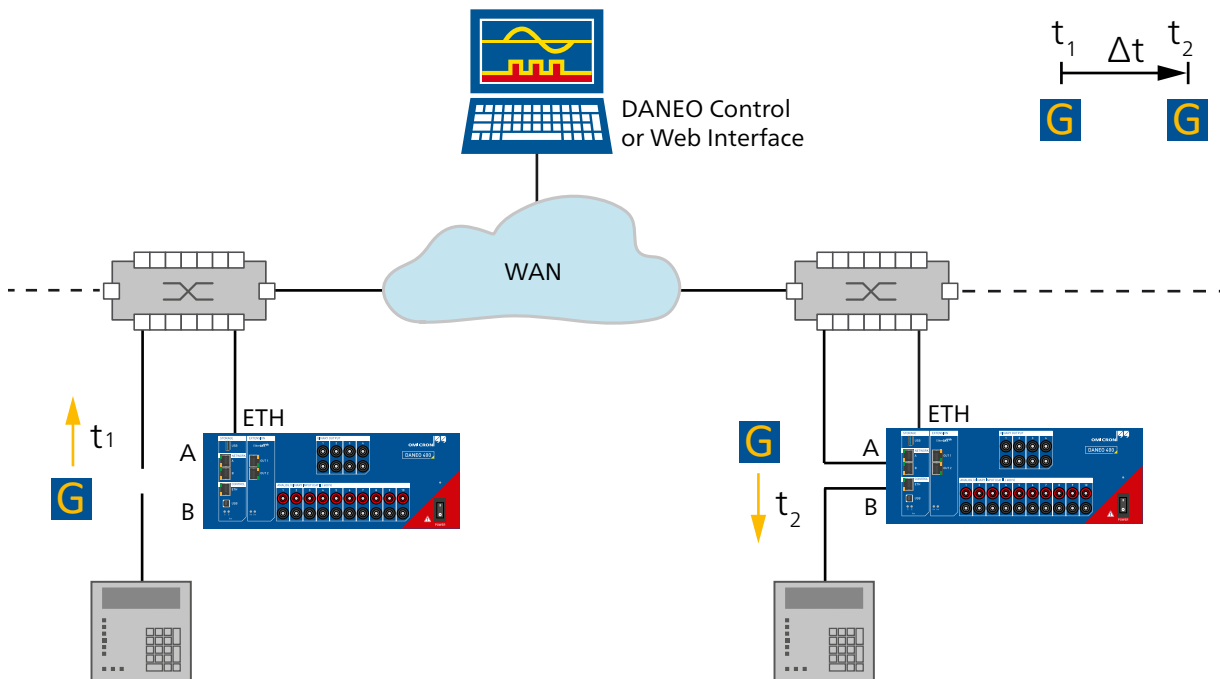

Redundancy networks

There are often redundancy mechanisms (e.g. HSR and PRP) used in PAC systems. DANEEO 400 can also measure packet timings in such network topologies.

DANEO Control – Data acquisition and analysis

The innovative DANEO Control is the PC software to easily control your DANEO 400 measurement system and analyze your recordings. It is divided into an Acquisition and Analysis workspace. All configurations and results can be saved in files, printed or stored in PDF/RTF format.

Data acquisition



In the acquisition workspace, you configure your measurement devices and IEDs of the system under test. You can import IED configurations from SCL files and find GOOSE and SV orphans on the network. The whole test setup is visualized in a network diagram. The IEC 61850 communication can easily be verified against the configuration and the supervisor detects abnormalities during the operation. Measurements for phase and power systems, binaries, and network load are available in the device signal pool. All signals can be observed live, recorded, and used in trigger conditions.

Acquisition tools



Event list			
Date and Time	Device	Category	
2015-10-16 15:49:35.049	DANEO 1 (AJ023D)	GOOSE	✖
2015-10-16 15:48:44.576	DANEO 1 (AJ023D)	Device	ⓘ
2015-10-16 15:48:43.109	DANEO 1 (AJ023D)	GOOSE	✖
2015-10-16 15:48:34.576	DANEO 1 (AJ023D)	Device	ⓘ

Details	
Severity	Error
Date and Time	2015-10-16 15:49:35.049
Device	DANEO 1 (AJ023D)
Category	GOOSE
Type	Out of sequence

Observation

The actual values and the most recent history of all signals in the pool are shown:

- > Measurement live values and recent history
- > Instantaneous value observation
- > Phasor diagrams
- > Relative phase values
- > Harmonics spectrum view

Recording

All signals from the pool and the network traffic are recorded. A recording is started manually or by a defined trigger condition:

- > Signals selection
- > Traffic filters configuration
- > Trigger condition and recording length settings
- > Post trigger action configuration
- > Storage location definition

Supervision

The network traffic is constantly supervised and the occurred events are logged in the devices:

- > Live event list
- > Details for selected events
- > Actions for specific events to trigger recordings or send email notifications

Data analysis



In the analysis workspace, you can analyze your recordings, view all supervisor events, and assess the performance of the substation network. It is easy to find and select the recordings and supervisor events on the time line. The data is collected from your devices or from local folders. If recordings are too large, just crop it for analyzing. Simply export your recordings into COMTADE and PCAP files to analyze the data with other tools.

Analysis tools

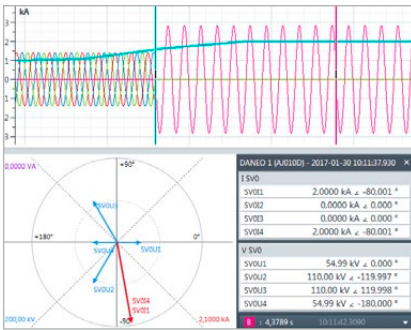

Time signal analysis

All recorded signals are available in an aggregated and time-aligned view for analysing the results:

- > Show time signals and phasors in diagrams
- > Harmonic spectrum view
- > Offer cursor values and calculations
- > GOOSE packet details for mapped binary signals
- > Post-calculated traffic signals for recorded PCAP files

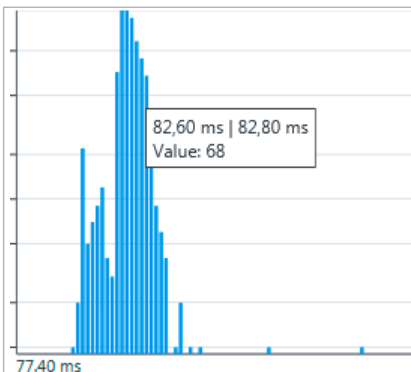

Propagation delay analysis

Calculation of propagation delay statistics for any kind of packets between two different locations in the network:

- > Selection of network packet and direction
- > Propagation delay statistic values (min, max, average, standard deviation)
- > Histogram diagram of delay values

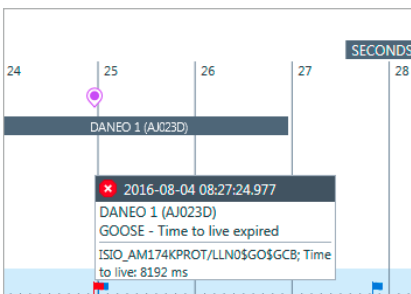

Supervisor event analysis

All events are shown on a time line together with the recordings. They can be analyzed, saved, and documented together:

- > Events on time line
- > Selected event in list with all details
- > User comments for documentation

Operating options

Web interface

The DANEO 400 has a built-in web interface. Certain functions of a single device can be accessed by simply connecting with a web browser. The supported feature set focuses on functions related to the traffic on the communication network. The device status can be checked and available recordings can be downloaded for further analysis. It is also possible to publish up to three Sampled Values streams.

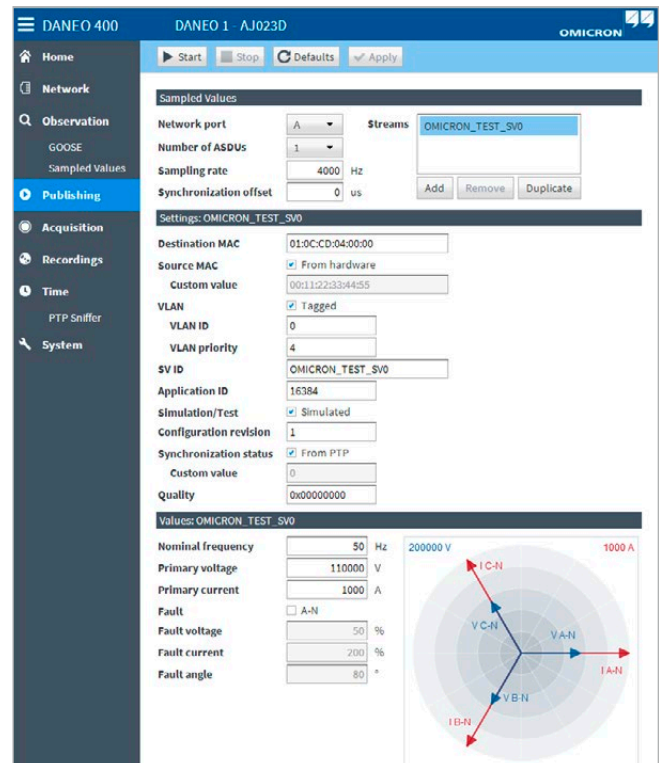

DANEO 400 web interface

Flexible housing

The housing of the DANEO 400 is very flexible. It can be configured for different working positions by rotating and moving the device handle.

For placing the DANEO 400 on the floor, the handle can be used as a stand. If the handle is not required (for example, when stacking multiple devices) you can easily move it to the rear of the DANEO 400.



DANEO 400 handle used as floor stand

Accessories

EXB1 binary I/O extension unit

The EXB1 extends the I/O capabilities of the DANEO 400 with 8 binary inputs and 8 binary outputs. The EXB1 units are connected to the DANEO 400 main unit via the extension interfaces.

www.omicronenergy.com/products/exb1



EMCON 200 ethernet media converter

The PTP transparent media converter EMCON 200 is used to connect the DANEO 400 to the optical fiber networks. It is powered over Ethernet (PoE) and SFP transceiver modules offer flexible configurations.

www.omicronenergy.com/emcon200



PTP grandmaster clock

In some cases a time synchronization of the involved DANEO devices is needed (e.g. distributed recording with multiple units). Dedicated PTP grandmaster clocks are required, if the PTP protocol is not available yet on the communication network. OMICRON offers the suitable accessories CMGPS 588 and OTMC 100p.

www.omicronenergy.com/cmgps588

www.omicronenergy.com/otmc100



Technical specifications

DANE0 400

Network interfaces

Network ports (A,B)	2 Ethernet ports 10/100/1000 Base-TX (RJ45); configurable as network TAP
---------------------	--

Control interfaces

Control port (ETH)	1 Ethernet port 10/100/1000 Base-TX (RJ45)
USB port	1 USB 2.0 device port; High-Speed (Type B)

Mass storage interface

USB port	1 USB 3.0 host port; SuperSpeed (Type A)
----------	--

Extension interfaces

Extension ports (OUT 1,2)	2 EtherCAT® ports (RJ45)
---------------------------	--------------------------

Analog inputs

Number	max. 10 (shared with binary inputs)
Sampling frequency	10 kHz or 40 kHz
Nominal ranges	10 mV, 100 mV, 1 V, 10 V, 100 V, 600 V
Measurement category	CAT II / 600 V CAT III / 300 V CAT IV / 150 V

Binary inputs

Number	max. 10 (shared with analog inputs)
Level detection	Potential-free contacts or DC voltage compared to threshold voltage
Input ranges	10 V (-10 V ... 10 V); 100 V (-100 V ... 100 V); 600 V (-600 V ... 600 V) default: 600 V
Sampling frequency	10 kHz
Time resolution	100 µs

Binary outputs

Number	4
--------	---

Internal storage

Technology	Solid State Disc (SSD)
Capacity	approx. 58 GB

Power supply

Voltage; nominal	100 – 240 VAC, 1-phase
Frequency; nominal	50/60 Hz
Power consumption	max. 100 W

Environmental conditions

Operating temperature	0 °C ... +50 °C +32 °F ... +122 °F
Storage and transportation	-25 °C ... +70 °C -13 °F ... +158 °F

Mechanics

Dimensions (W x H x D, without handle)	345 mm x 140 mm x 390 mm 13.6 in x 5.7 in x 15.4 in
Weight	7.0 kg 15.4 lbs
Ingress protection	IP30 according to EN 60529

Ordering Options



	Description	Item no.
DANEO 400 Basic	Signal Analyzer for Power Utility Automation Systems. Measuring and recording conventional (analog and binary) signals	P0006500
DANEO 400 Standard	Hybrid Signal Analyzer for Power Utility Automation Systems. Measuring and recording conventional (analog and binary) signals and traffic from power utility communication networks (IEC 61850 GOOSE and Sampled Values)	P0006501
Upgrade	from DANEO 400 Basic to DANEO 400 Standard	P0006503
EXB1	Binary I/O extension unit for DANEO 400 which offers an additional eight binary inputs and outputs	P0006502
EMCON 200	Ethernet media converter used for connecting optical fiber and twisted pair copper Ethernet networks	P0006504
CMGPS 588	Antenna-integrated IEEE 1588-2008/PTP grandmaster clock optimized for outdoor usage supporting the power profile according to IEEE C37.238-2011	P0006433
OTMC 100p portable	Antenna-integrated IEEE 1588-2008/PTP grandmaster clock and NTP time server for applications in the power industry supporting the power profile according to IEEE C37.238-2011	P0006508



We create customer value through ...

Quality

You can rely on the highest safety and security standards



Superior reliability with up to

72

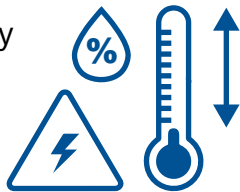

hours burn-in tests before delivery

100%

routine testing for all test set components

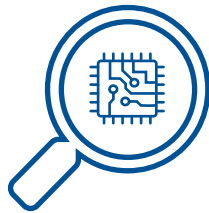

ISO 9001
TÜV & EMAS
ISO 14001
OHSAS 18001



Compliance with international standards

Innovation



... a product portfolio tailored to my needs

More than

200

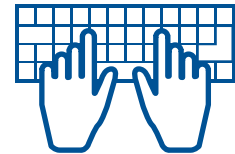

developers

keep our solutions up-to-date

More than

15%



of our annual sales is reinvested in research and development

Save up to

80%



testing time through templates, and automation

— Support —



Professional technical support at any time

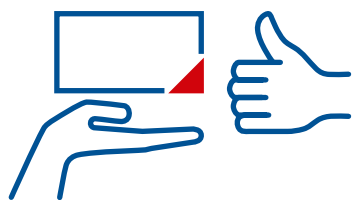

Loaner devices help to reduce downtime

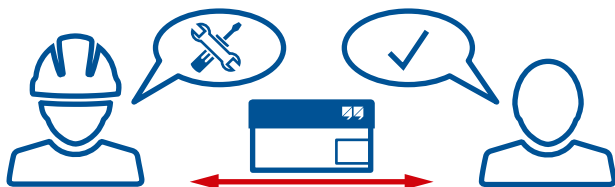

Cost-effective and straight-forward repair and calibration



offices worldwide for local contact and support

— Knowledge —

More than

300



Academy and numerous hands-on trainings per year

Frequently OMICRON hosted user meetings, seminars and conferences



to thousands of technical papers and application notes

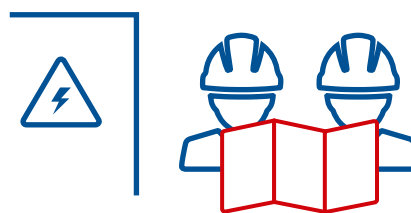

Extensive expertise in consulting, testing and diagnostics

OMICRON is an international company that works passionately on ideas for making electric power systems safe and reliable. Our pioneering solutions are designed to meet our industry's current and future challenges. We always go the extra mile to empower our customers: we react to their needs, provide extraordinary local support, and share our expertise.

Within the OMICRON group, we research and develop innovative technologies for all fields in electric power systems. When it comes to electrical testing for medium- and high-voltage equipment, protection testing, digital substation testing solutions, and cybersecurity solutions, customers all over the world trust in the accuracy, speed, and quality of our user-friendly solutions.

Founded in 1984, OMICRON draws on their decades of profound expertise in the field of electric power engineering. A dedicated team of more than 1250 employees provides solutions with 24/7 support at 22 locations worldwide and serves customers in more than 170 countries.

For more information, additional literature, and detailed contact information of our worldwide offices please visit our website.